

No. 660,978.

Patented Oct. 30, 1900.

A. TINDEL & O. ALBRECHT.
CRANK PIN TURNING ATTACHMENT FOR LATHES.

(Application filed Jan. 8, 1900.)

(No Model.)

3 Sheets—Sheet 1.

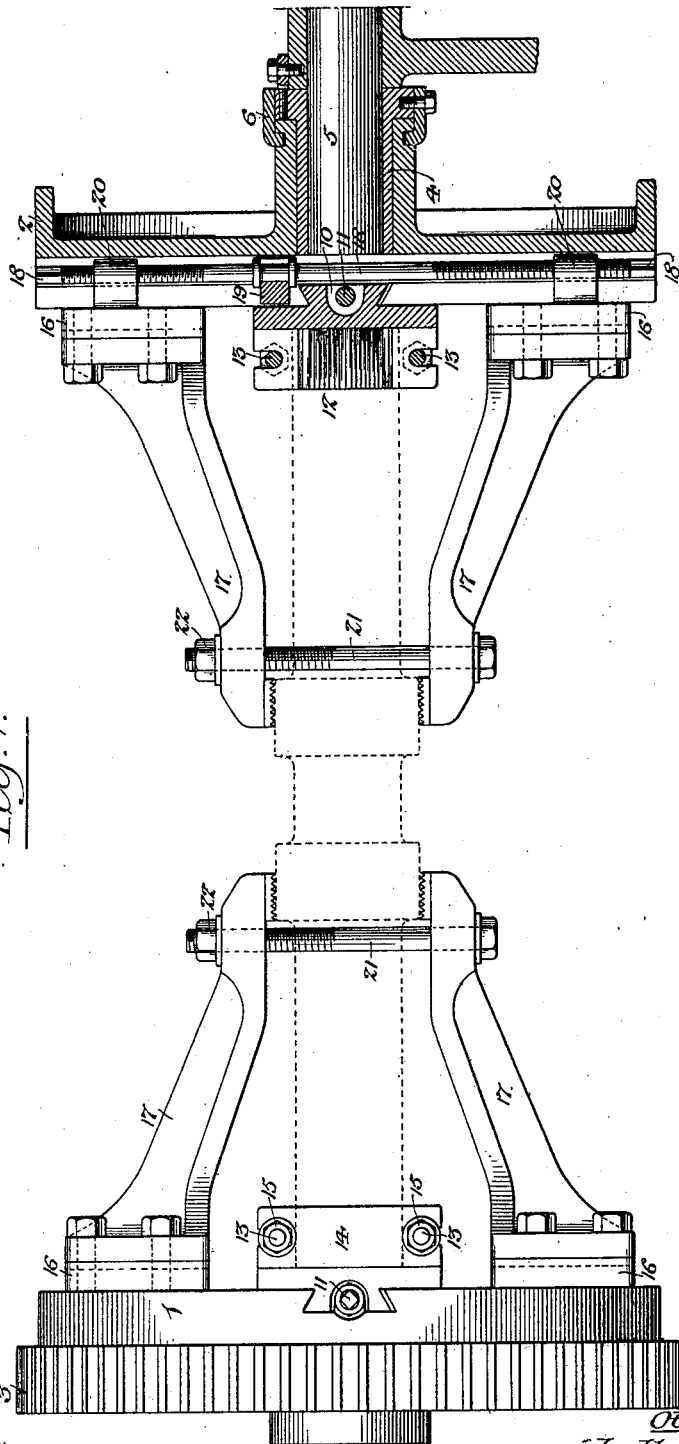

Fig. 1.

Witnesses:
Charles Nelson.
Lewis M. Whithead.

Inventors:
Adam Tindel.
Otto Albrecht.
by their Attorneys:
Hosmer & Hosmer

No. 660,978.

Patented Oct. 30, 1900.

A. TINDEL & O. ALBRECHT
CRANK PIN TURNING ATTACHMENT FOR LATHES.

(Application filed Jan. 8, 1900.)

(No Model.)

3 Sheets—Sheet 2.

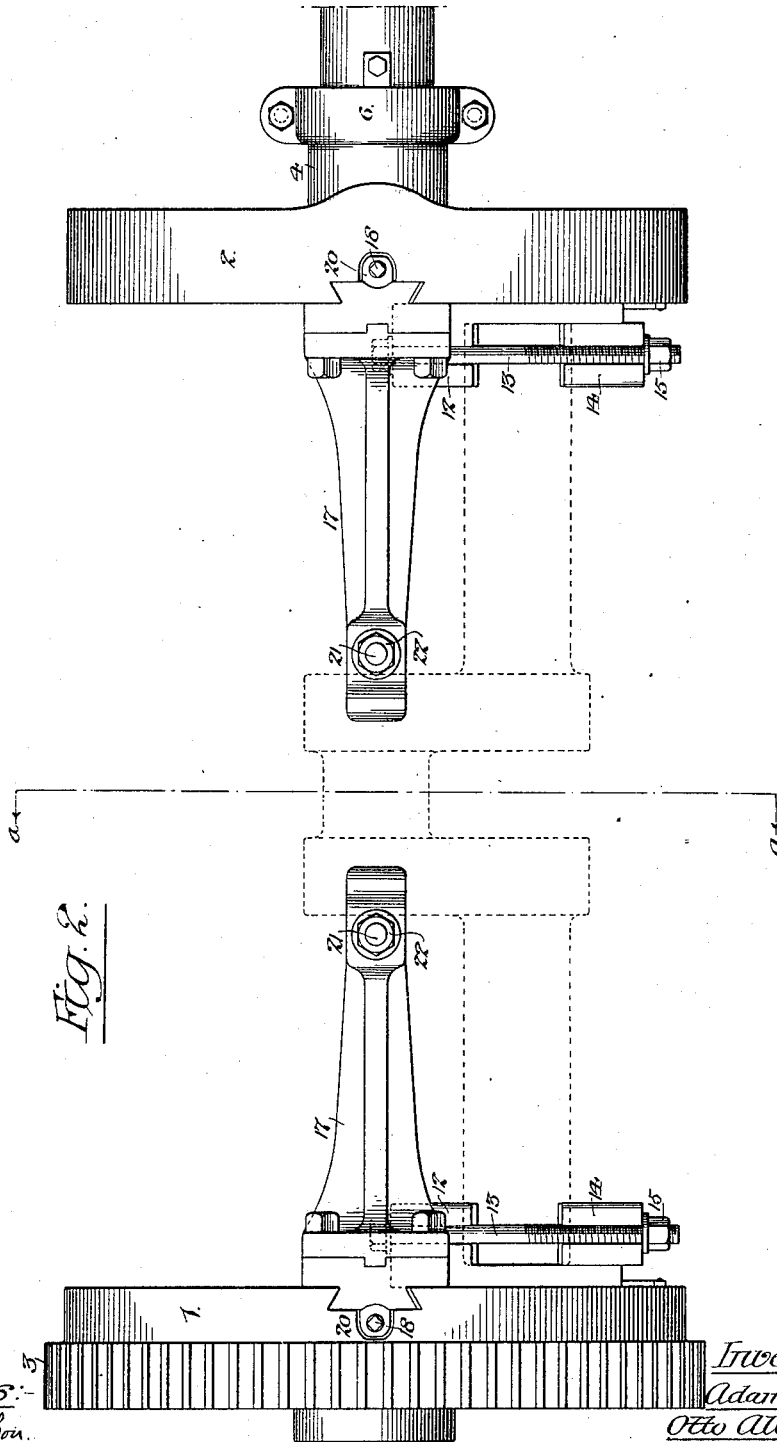

Fig. 2.

Witnesses:
Charles DeBon.
Louis H. Whitelock.

Inventors:
Adam Tindel.
Otto Albrecht.
by their Attorneys:
Houston & Houston

UNITED STATES PATENT OFFICE.

ADAM TINDEL AND OTTO ALBRECHT, OF PHILADELPHIA, PENNSYLVANIA.

CRANK-PIN-TURNING ATTACHMENT FOR LATHES.

SPECIFICATION forming part of Letters Patent No. 660,978, dated October 30, 1900.

Application filed January 8, 1900. Serial No. 739. (No model.)

To all whom it may concern:

Be it known that we, ADAM TINDEL and OTTO ALBRECHT, citizens of the United States, and residents of Philadelphia, Pennsylvania, have invented certain Improvements in Crank-Pin-Turning Attachments for Lathes, of which the following is a specification.

The object of our invention is to provide means whereby an ordinary turning-lathe may be readily adapted for turning crank-pins or eccentrics—an object which we attain in the manner hereinafter set forth, reference being had to the accompanying drawings, in which—

Figure 1 is a side view, partly in section, of the parts comprising our invention. Fig. 2 is a top or plan view of the same. Fig. 3 is a section on the line *a a*, Fig. 2; and Fig. 4 is a side view illustrating a special feature of our invention.

As represented in Fig. 1, the attachment comprises two face-plates 1 and 2, the face-plate 1 being intended for application to the lathe-mandrel in place of the ordinary face-plate and being provided with a spur-gear 3, whereby it may be rotated by the gearing of the lathe. The face-plate 2 is mounted so as to be free to turn upon a sleeve 4, which is mounted so as to be incapable of turning upon the tail-stock or dead-spindle 5 of the lathe, a clasp-ring 6 being secured to said sleeve and engaging with a groove in the hub of the face-plate 2, so as to retain the latter in position longitudinally. Each of the face-plates carries a set of crank-shaft chucking and gripping devices, and as these devices are the same on each face-plate a description of one set will suffice. The face-plate has dovetailed grooves 7 and 8 crossing each other at right angles, the groove 7 serving as a guide for the shaft-chucking device and the groove 8 serving as a guide for a pair of crank-arm-clamping jaws.

The chucking device comprises a slide 9, having a dovetailed rib for engagement with the dovetailed groove 7, and also having a nut 10 for engagement with an adjusting-screw 11, which is confined longitudinally to a suitable stud on the face-plate, so that by turning said screw the chuck-slide can be caused to move toward or from the center of the face-plate.

Secured to or forming part of the slide 9 is the fixed jaw 12 of the chuck, which is slotted for the reception of a pair of clamp-bolts 13, said bolts being adapted to like slots in the movable jaw 14 of the chuck, so that by manipulating nuts 15 on said bolts the chuck-jaws can be caused to securely clamp the crank-shaft, as shown by dotted lines in Figs. 2 and 3, the radial position of the chuck-slide 9 on the face-plate being dependent upon the throw of the crank, it being understood that the axial line of the crank-pin is coincident with the axis of the face-plate.

The groove 8 of the face-plate receives dovetailed ribs upon a pair of slides 16, each of which has a projecting arm 17, forming a clamp-jaw for engagement with an arm of the crank, the slides being caused to approach and recede from the axis of the face-plate by means of a screw-stem 18, which is longitudinally confined to a stud 19 on the face-plate, and has a right-hand threaded portion for engagement with a nut 20 on one of the slides 16 and a left-hand threaded portion for engagement with a similar nut on the other slide 16.

The outer ends of the arms 17 have openings for the reception of a transverse bolt 21, which is provided with a nut 22. Hence when the slides 16 have been adjusted to such positions as to cause the clamp-jaws at the outer ends of the arms 17 to bear upon the arms of the crank, as shown in Figs. 1 and 2, said jaws may be caused to firmly grip the crank-arms by tightening the nuts 22, a much firmer hold upon the crank-arm being thus insured than if reliance were placed wholly upon the inward movement of the slides 16 under the action of the screw-stem 18 for effecting this result.

The construction described provides a simple and convenient attachment whereby an ordinary turning-lathe can be readily adapted for the turning of crank-pins.

If desired, the chuck-slide 9 may be provided with a center pin 23, as shown in Fig. 4, and the chuck may be adjusted so as to serve as a center chuck for the lathe.

We have shown the device as applied to a shaft having a single crank; but it will be evident that it can be applied as well to shafts having a series of cranks.

Having thus described our invention, we claim and desire to secure by Letters Patent—

- 5 1. The combination of a lathe cross-head with means for chucking a crank-shaft, and a pair of adjustable slides each having a projecting arm forming a clamp-jaw for engaging with a crank-arm of said shaft, substantially as specified.
- 10 2. The combination of a lathe face-plate with a radially-adjustable chucking device for a crank-shaft, and a pair of adjustable slides each having a projecting arm forming a clamp-jaw for engaging with a crank-arm of said shaft, substantially as specified.
- 15 3. The combination of a lathe face-plate with means for chucking a crank-shaft, a pair of adjustable slides each having a projecting arm forming a clamp-jaw for engaging with

a crank-arm of said shaft, and a clamping-bolt whereby the outer ends of said arms may be drawn together, substantially as specified. 20

4. The combination in a crank-pin-turning attachment for lathes, of a positively-rotated face-plate and a face-plate mounted so as to be free to turn on the tail-stock, or dead-spindle of the lathe, with shaft-chucking mechanism, and pairs of adjustable crank-arm-gripping jaws, one pair on each of said face-plates, substantially as specified. 25 30

In testimony whereof we have signed our names to this specification in the presence of two subscribing witnesses.

ADAM TINDEL.
OTTO ALBRECHT.

Witnesses:

FRANK E. BECHTOLD,
JOS. H. KLEIN.